

MB-E B

Technical data

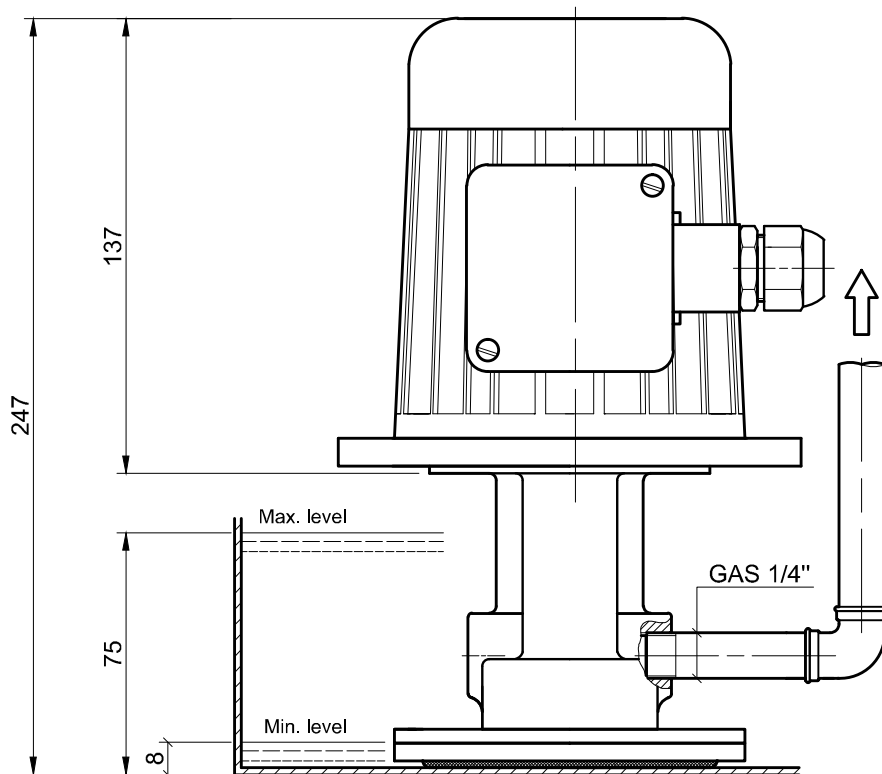

DESCRIPTION

Type MB-E B gear pumps have been specially designed for the collection of oils in trays where the oil depth is minimum.

FEATURES

This pump is composed by an asynchronous three-phase motor, and a small gear pump of high quality and reliability.

The suction is located at the bottom of the pump, where there is a filter mesh, which is convenient to clean every 100 hours of work under normal conditions, or even before in filthy conditions.

This pump is equipped with mechanical seal, so it is important that its use is only when it has been liquid in the tray.

Gear electropump data

Type	Q [l/min]	H [m]	Net weight [kg]	Noise level [dB]
MB-E B	1	1	5,5	58 - 62

Electrical data

Type	Rated power [kW]	Rated voltage [V]	Rated Frequency [Hz]	Rated current [A]	Rated speed [rpm]
MB-E B	0,08 0,08	230 / 400 460	50 60	0,44 / 0,25 0,25	1450 1750



CMI, S.A.